



## CANTILEVER BEER CAVE RACK SYSTEM



Patent # 20230240454



IMAGEWORKS  
DISPLAY

800.704.3660

[imageworksdisplay.com](http://imageworksdisplay.com)



## CANTILEVER BEER CAVE RACK SYSTEM

- Available in 2ft, 3ft & 4ft shelf widths
- Available in 24-inch or 30-inch shelf depths @ 60-inch height
- Available in 24-inch shelf depths @ 72-inch height
- 30-inch deck depth can be used with 24-inch deep shelves
- Options available for wire and sheet metal shelves & decks
- Corner shelves and back panels are available



IMAGEWORKS  
DISPLAY

800.704.3660

[imageworksdisplay.com](http://imageworksdisplay.com)



Available in the Following Size Options:

### 60-Inch High x 30-Inch Deep Shelves

60-inch high uprights

30-inch deep deck and shelves

(1) deck

(3) shelves per section, maximum (4-tier system)

A 30-inch shelf accommodates (240) 12oz glass bottles or 300 lbs.

A 30-inch base deck accommodates (960) 12oz glass bottles or 1200 lbs.

**Total Capacity = 2,100 lbs**

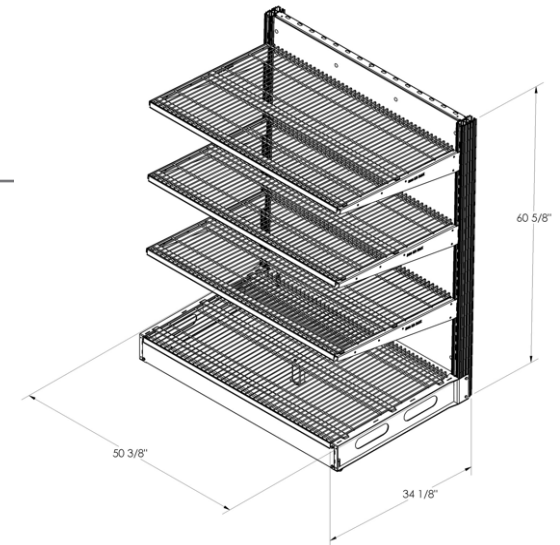

### 60-Inch High x 24-Inch Deep Shelves

60-inch high uprights

24-inch or 30-inch deep deck and 24-inch deep shelves

(1) deck

(3) shelves per section, maximum (4-tier system)

A 24-inch shelf accommodates (200) 12oz glass bottles or 250 lbs.

A 24-inch or 30-inch base deck accommodates (960) 12oz glass bottles or 1200 lbs.

**Total Capacity = 1,950 lbs.**

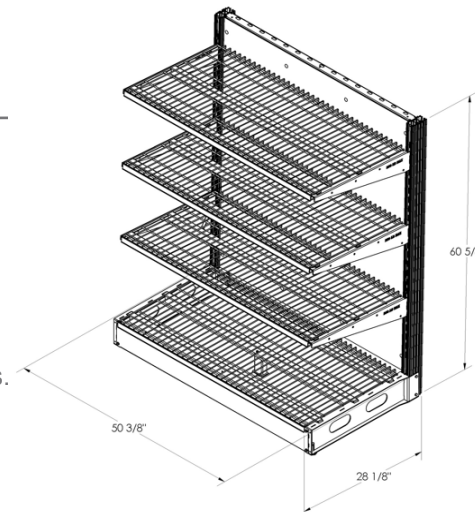

### 72-Inch High x 24-Inch Deep Shelves

72-inch high uprights

24-inch or 30-inch deep deck and 24-inch deep shelves

(1) deck

(4) shelves per section, maximum (5-tier system)

A 24-inch shelf accommodates (200) 12oz glass bottles or 250 lbs.

A 24-inch or 30-inch base deck accommodates (960) 12oz glass bottles or 1200 lbs.

**Total Capacity = 2,200 lbs.**

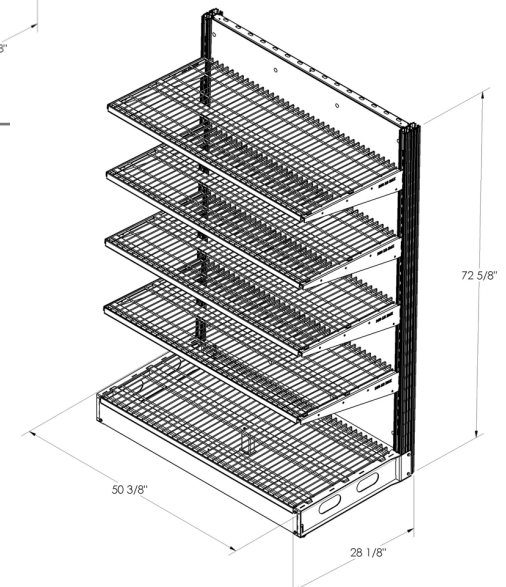

800.704.3660

[imageworksdisplay.com](http://imageworksdisplay.com)